

# Performance Assessment of a Dense Membrane Aerated Biofilm Reactor for Nitrogen Removal from Municipal Wastewater

Michael Yitages<sup>1</sup>, Nabin Ariyal<sup>1</sup>, Melesse Eshetu<sup>2</sup>, Tonje Marita Bjerkan Heggeset<sup>3</sup>, Tone Haugen<sup>3</sup>, Marius Sandru<sup>3</sup> Eugenia Mariana Sandru<sup>3</sup>, Eshetu Janka<sup>1\*</sup>

<sup>1</sup> University of South-Eastern Norway (USN), Kjølnes ring 56, 3918, Porsgrunn.

<sup>2</sup> Scandinavian Water Technology AS

<sup>3</sup> SINTEF Industry, Norway

\*Corresponding author email: [eshetu.j.wakjera@usn.no](mailto:eshetu.j.wakjera@usn.no)

## Introduction

- The Energy Efficient and Sustainable Wastewater Treatment (ESWAT) project aims to develop sustainable technology for removing nitrogen-rich compounds, such as ammonia, and pharmaceutically active compounds (PhACs) from wastewater using membrane biofilm reactors and enzyme technology.
- Strict European nitrogen discharge regulation requires more efficient wastewater treatment technologies.
- Conventional biological treatment has limited nitrogen removal efficiency and high energy demand mainly aeration.
- Aeration is energy intensive, accounting approximately 45-75% of the plant's energy consumption cost.
- Membrane aerated biofilm reactor (MABR) is an emerging biological wastewater treatment technology.
- MABR can reduce 70-90% of aeration energy.

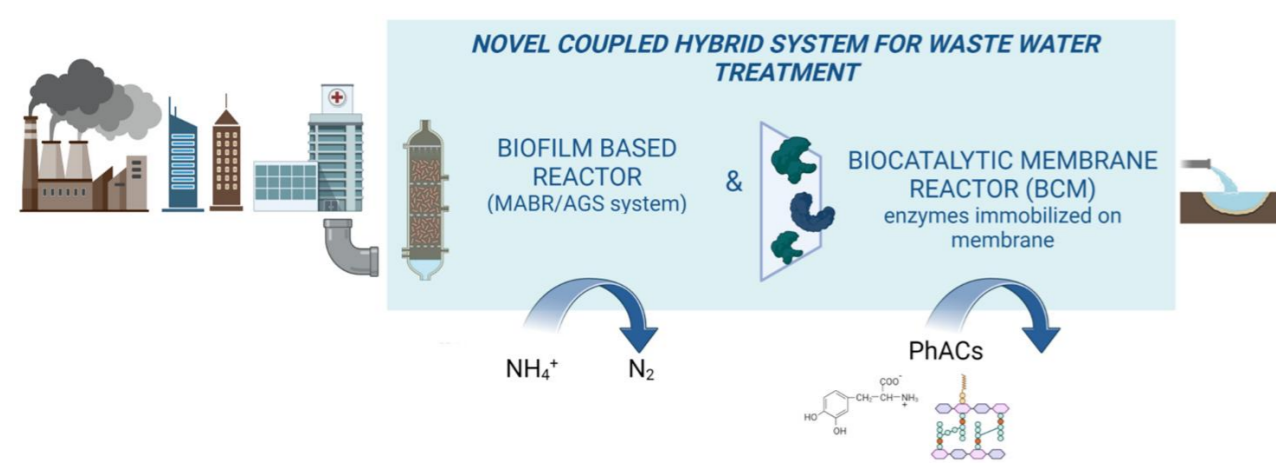

## Research Questions

- RQ-I. How efficient are MAB reactors in nitrogen removal and energy use?
- RQ-II. Is the enhanced nitrification and anaerobic ammonium oxidation process efficient in nitrogen removal in MAB reactors?
- RQ-III. How can an integrated biofilm-enzyme reactor be designed using the MAB reactors?

## Material and Methods

### 1. Reactor design and membrane fitting

- Membrane used: Polydimethylsiloxane (PDMS), dense and hydrophobic hollow fiber.

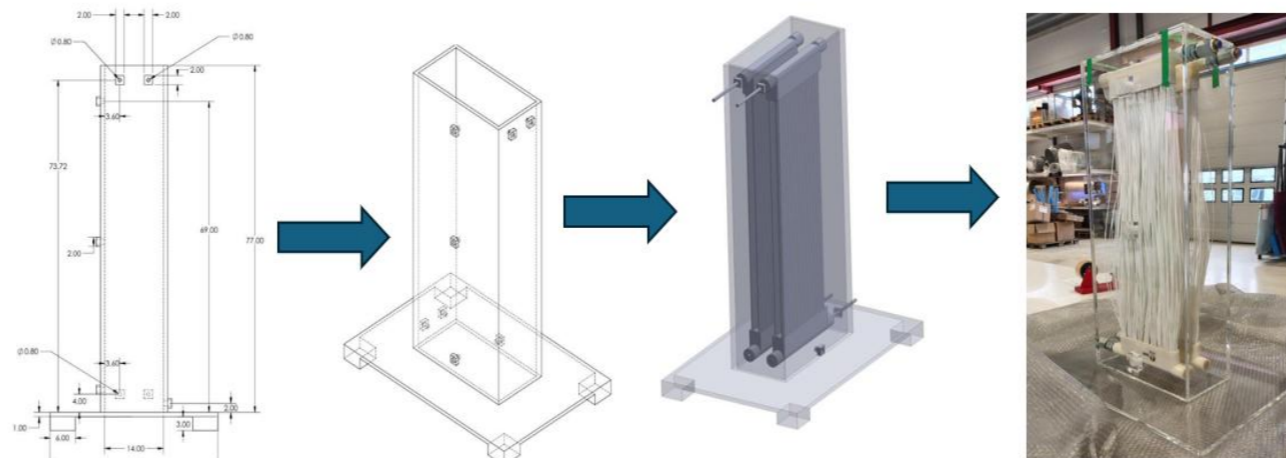

### 2. Reactor setup and operation

- Reactor working volume 30 L.

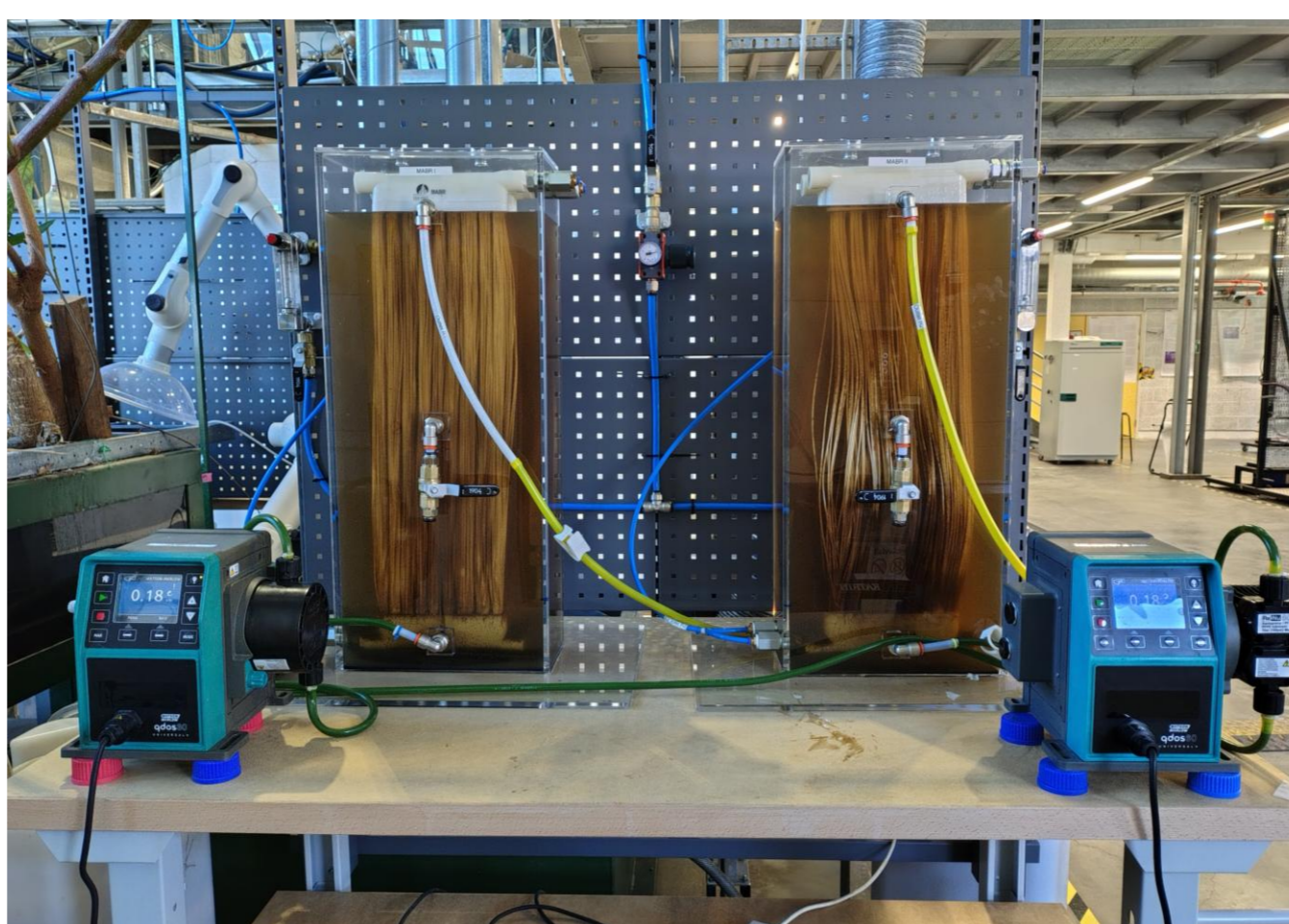

### 3. Data collection and analysis



- Total and Soluble chemical oxygen demand - **photometric Spectroquant**
- NH4-N, NO2-N, NO3-N – **photometric Spectroquant**
- pH, Dissolved oxygen (DO) – **Portable Oxi 3310 DO meter and Hanna pH meter.**
- Alkalinity - **photometric Spectroquant**
- DNA – Sampling -**SINTEF**
- Mass-balance analysis

## Results

- NH<sub>4</sub>-N removal was achieved through CN process with 86.5% in MABR-I and 81.5% in MABR-II, respectively.
- NO<sub>3</sub>-N accumulated, but the denitrification process was limited.
- The Lower pH and alkalinity were observed, confirming the CN process.
- The tCOD and sCOD removal improved, reaching 60.0% and 25.0% in MABR-I and 59.5% and 23.0% in MABR-II, respectively.
- Unexpectedly, the DO increased during operation and reached 5.3 mg/L in MABR-I and 4.5 mg/L in MABR-II, respectively.

Parameter	Specification/Value	Unit
Membrane Material	PDMS	-
Effective Membrane Area	1.2	m <sup>2</sup>
Fiber outer diameter	2.0 ± 0.1	mm
Hydraulic retention time	7	days
Oxygen transfer Efficiency (OTE)	100	Percent (%)
Air flow rate	5	N L/m
Air pressure	1.5 ± 0.3	bars

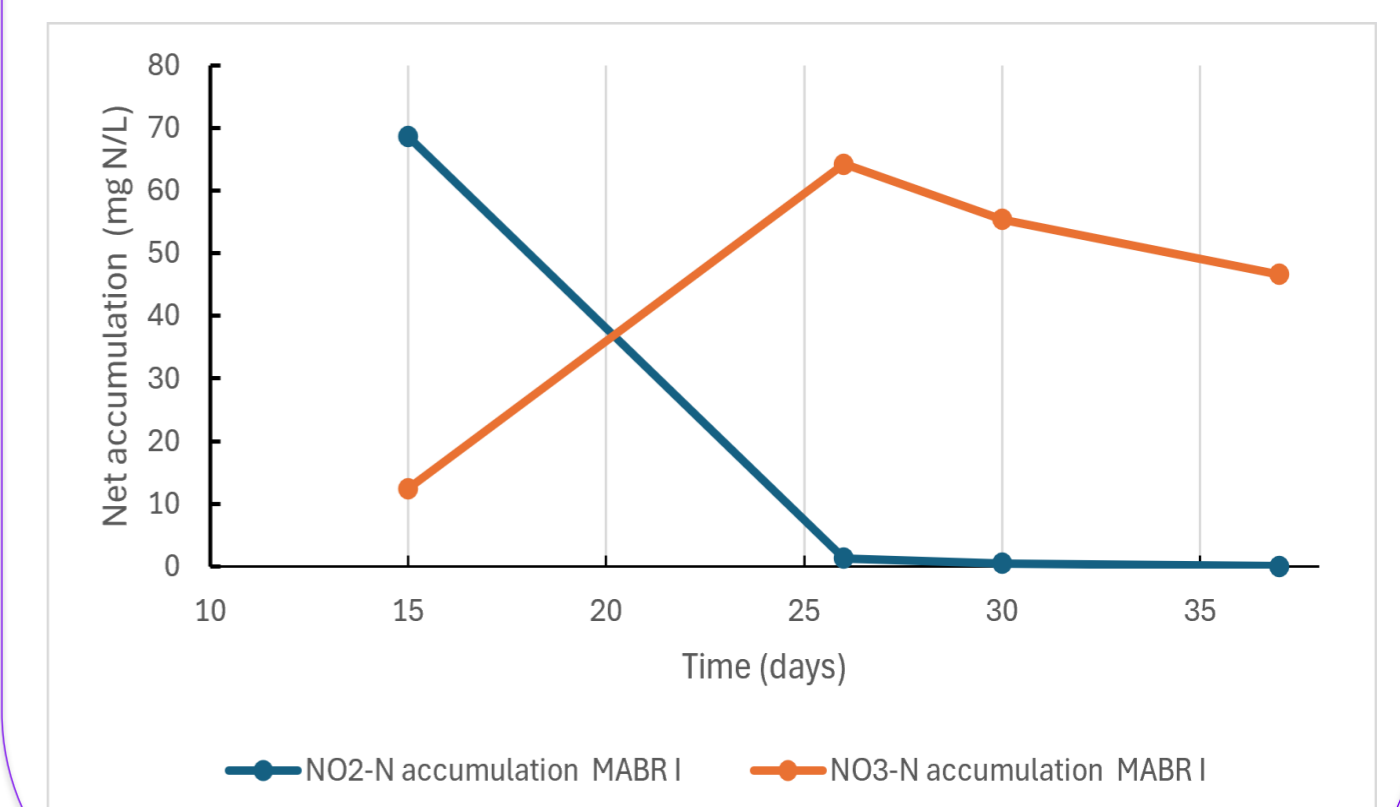
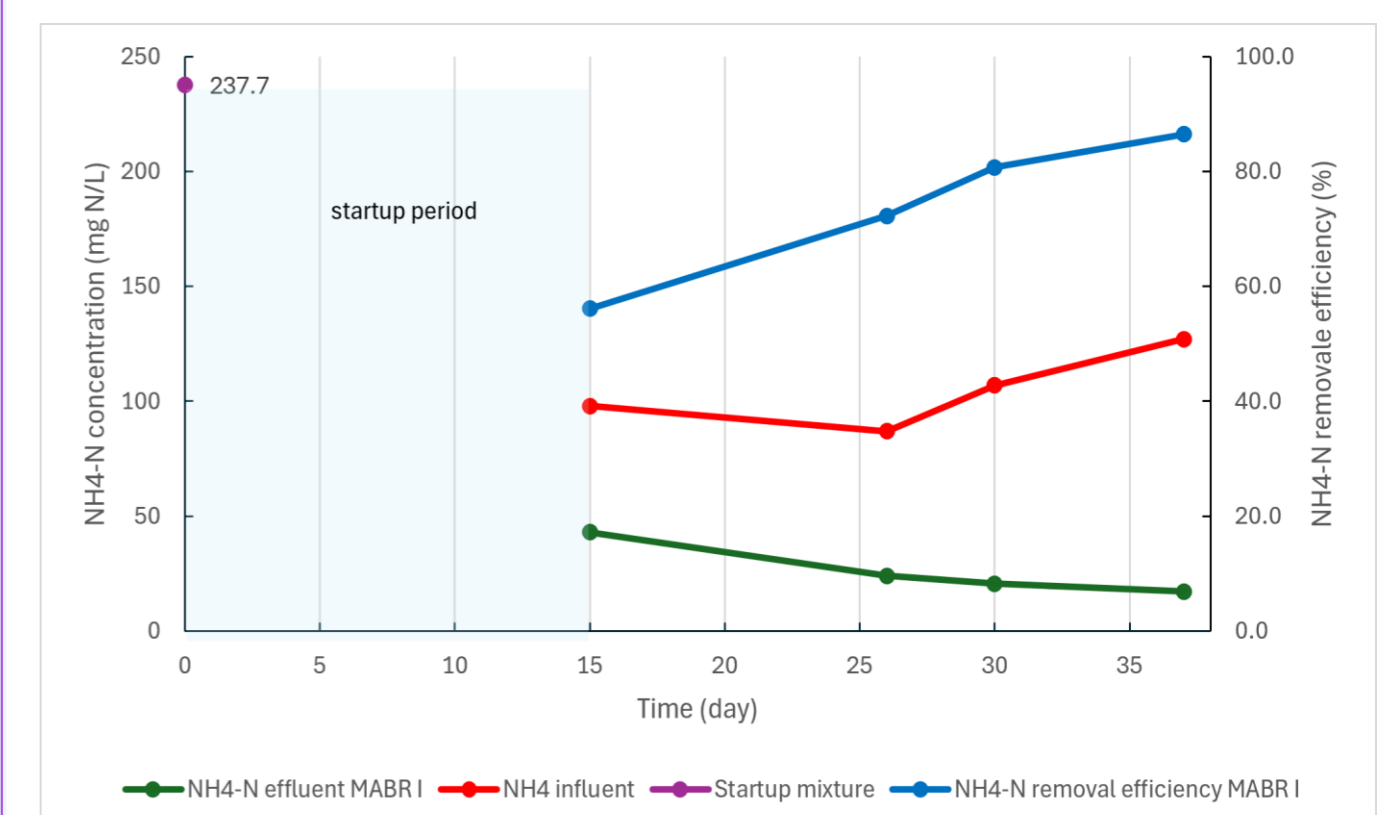

## MABR System

- MABR uses bubbleless gas-permeable membrane to deliver oxygen.
- Oxygen and substrates diffuse into the attached biofilm through counter-diffusional mechanism.
- This mechanism creates a stratified biofilm structure, and can achieve CN, SND, PND, and PNA processes.

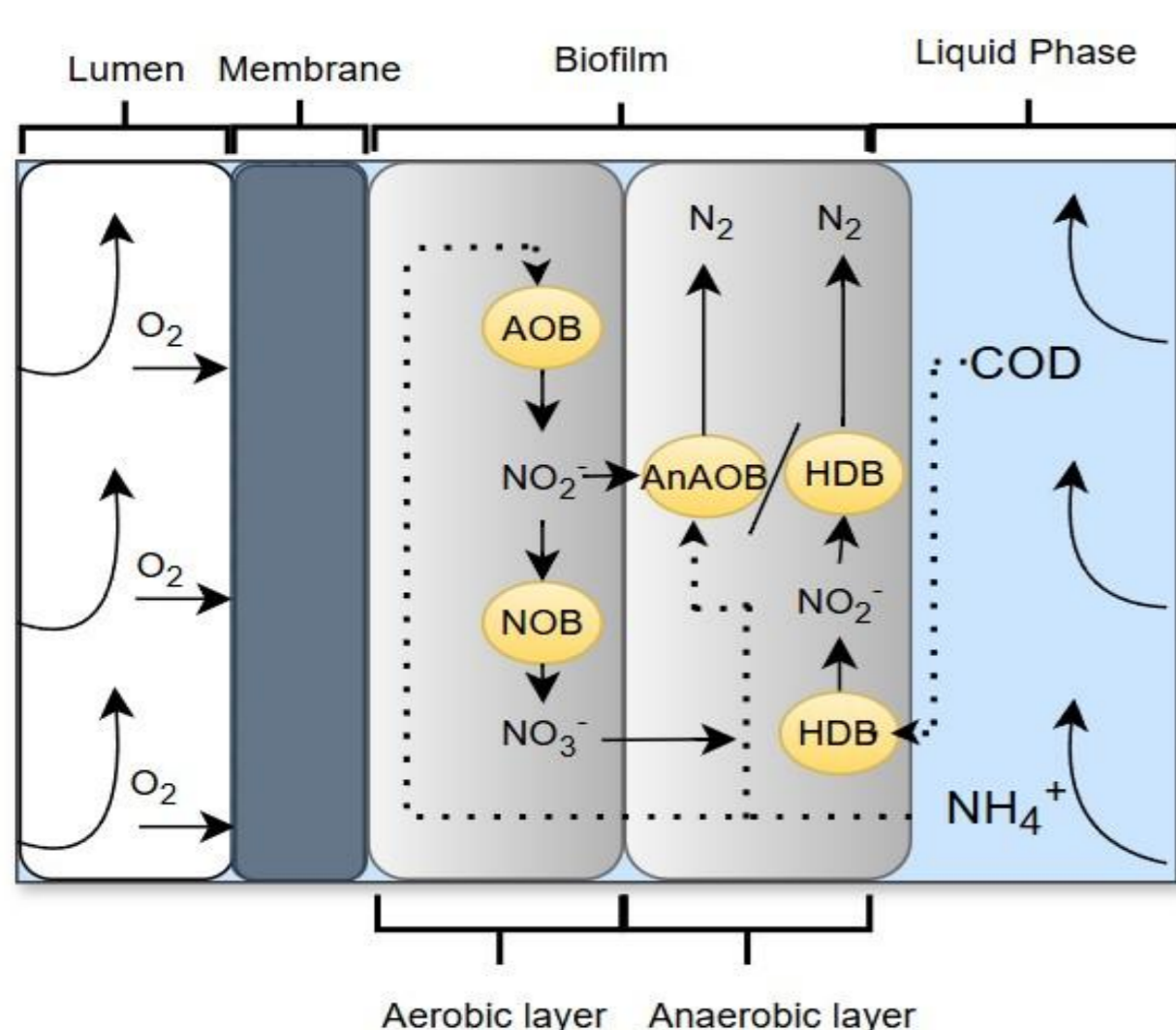

### N- removal: nitrification-denitrification

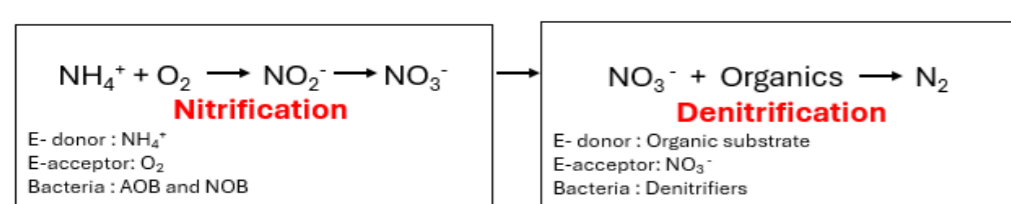

### N- removal: partial nitrification-anammox

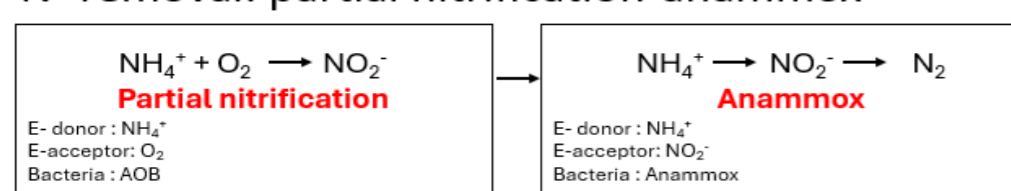

## Conclusion

- Nitrification process dominated in both reactors, with limited denitrification. **Partly answered RQ-I**
- Membrane pressure difference should be regulated to control DO properly.
- Control of exhaust air to improve oxygen transfer efficiency (OTE).
- Mass balance analysis of nitrification, denitrification, and anammox processes for efficient energy use.
- The research is ongoing to address the RQ II and RQ III.